



Wi-Fi INTERFACE

Model **MAC-567IF-E**



INSTALLATION MANUAL

English(GB)

Contents

1. Safety precautions.....	1
2. Product Introduction	5
3. Parts	5
4. Connecting the Wi-Fi interface	6
5. Specifications	8

About Wi-Fi interface

This Wi-Fi interface, communicates the status information and controls the commands from the MELCloud by connecting to an indoor unit.

- Some indoor units are not compatible with the Wi-Fi interface. Make sure that the indoor unit is compatible with the Wi-Fi interface before attempting to install the Wi-Fi interface.

Note [ATW (Air-to-water) indoor unit only]:

The software of ATW indoor unit needs to be upgraded before using the Wi-Fi interface.

Refer to the website of MELCloud for information about the models that need to be upgraded and the way to obtain and upgrade the software.

1. Safety precautions

- Read all Safety Instructions before installation, setting up, or use of the Wi-Fi interface.
- This installation manual contains important safety information. Be sure to comply with the instructions.
- After installing the Wi-Fi interface, provide this installation manual for the user. Instruct users to store it with their indoor unit instruction manual in a safe location.

[Precautions for installation]

Warning

(Improper handling may have serious consequences, including serious injury or death.)

- **Do not install the Wi-Fi interface by yourself (user).**
Improper installation may result in fire, electric shock, injury due to fall of the Wi-Fi interface, or water leaks. Consult the dealer from whom you purchased the Wi-Fi interface or professional installer.
- **The Wi-Fi Interface should be securely installed in accordance with this installation manual.**
Improper installation may result in fire, electric shock, or damage, or fall of the Wi-Fi interface.
- **The Wi-Fi interface should be mounted in a location that can support its weight.**
If the Wi-Fi interface is installed in a location that cannot support its weight, the Wi-Fi interface could fall and cause damage.
- **Connect and fasten the electric wires securely so external force on the wires will not apply on the terminals.**
Improper connection and mounting may result in breakdown, heat generation, smoke generation, or fire.
- **Mitsubishi Electric's components or other designated components must be used for installation.**
Improper component may result in fire, electric shock, or damage/water leaks.
- **Electric work must be performed by authorized personnel in accordance with the local regulations and the instructions detailed in the installation manual.**
- **Inadequate circuit capacity or improper installation may result in electric shock or fire.**
- **Do not connect the Wi-Fi interface to earth inside the indoor unit.**
- **Attach the electrical cover to the indoor unit securely.**
If the electrical cover of the indoor units is not attached securely, it could result in a fire or an electric shock due to dust, water, etc.
- **When installing the Wi-Fi interface, use appropriate protective equipment and tools for safety.**
Failure to do so could cause injury.
- **Turn off the breaker or unplug the power supply plug of the indoor unit when connecting the Wi-Fi interface.**
Failure to do so could cause electric shock.
- **Make sure to connect the connector of the Wi-Fi interface to the P.C. board of the indoor unit properly.**
Incomplete connecting or mounting may result in broken wire, heat generation, smoke generation, or fire.
- **Do not install the Wi-Fi interface nearby the automatic control devices such as automatic doors or fire alarms.**
It can cause accidents due to malfunctions.
- **Do not disassemble, modify, or repair by yourself.**
It can cause electric shock, fire, or injury.

Warning

(Improper handling may have serious consequences, including serious injury or death.)

- **Do not use the Wi-Fi interface nearby the medical electrical equipment or people who have a medical device such as a cardiac pacemaker or an implantable cardioverter-defibrillator.**
It can cause an accident due to malfunctions of the medical equipment or device.
- **This equipment should be installed and operated with a minimum distance of 20 cm between the device and the user or bystanders.**





Caution

(Improper handling may have consequences, including injury or damage to building.)

- **To prevent damage from static electricity, touch a nearby metal body to discharge static electricity from yourself before touching the Wi-Fi interface.**
Static electricity from the human body may damage the Wi-Fi interface unit.
- **Do not install the Wi-Fi interface in a place with much steam, such as bathroom.**
Avoid places where water is splashed or where condensation forms on walls. Installing in such places can cause electric shock or breakdown.
- **Do not install the Wi-Fi interface in places with direct sunlight or where the ambient temperature is 40°C or more or is 0°C or less.**
Direct sunlight and high or low temperature environments may cause the Wi-Fi interface to deform or breakdown.
- **Do not use in special environments.**
Use in places with much oil (including machine oil), steam, or sulfuric gas may lead to severe decrease in functionality and damage to parts.
- **Turn off power supply of connected equipment when performing construction or wiring work.**
Failure to turn off the power supply to the connected equipment may lead to malfunction or breakdown of the Wi-Fi interface or connected equipment.
- **The connecting cable must not touch piping directly.**
- **Do not use the Wi-Fi interface nearby other wireless devices, microwaves, cordless phones, or facsimiles.**
It can cause malfunctions.
- **Do not mount the Wi-Fi interface where children can reach.**
It can cause injury.





[Precautions for setting up, or use of the Wi-Fi interface]

■ Meanings of symbols used in this manual

 Be sure not to do.	 Be sure to follow the instruction.
 Never touch with wet hand.	 Be sure to disconnect the power supply plug from the power outlet.
 Never splash water on the unit.	

Warning

(Improper handling may have serious consequences, including serious injury or death.)

	<ul style="list-style-type: none"> ■ Do not disassemble, modify, or repair by yourself (user). It can cause electric shock, fire, or injury. 		<ul style="list-style-type: none"> ■ Do not touch the Wi-Fi interface with wet hands. It can cause damage to the device, electric shock, or fire.
	<ul style="list-style-type: none"> ■ This appliance is not intended for use by persons (including children) with reduced physical, sensory or mental capabilities, or lack of experience and knowledge, unless they have been given supervision or instruction concerning use of the appliance by a person responsible for their safety. 		<ul style="list-style-type: none"> ■ Do not splash water on the Wi-Fi interface or use it in a bathroom. It can cause damage to the device, electric shock, or fire.
	<ul style="list-style-type: none"> ■ Children should be supervised to ensure that they do not play with the appliances. 		<ul style="list-style-type: none"> ■ Do not install the Wi-Fi interface by yourself (user). Improper installation may result in fire, electric shock, or injury due to fall of the Wi-Fi interface. Consult the dealer from whom you purchased the Wi-Fi interface or professional installer.
	<ul style="list-style-type: none"> ■ This appliance can be used by children aged from 8 years and above and persons with reduced physical, sensory or mental capabilities or lack of experience and knowledge if they have been given supervision or instruction concerning use of the appliance in a safe way and understand the hazards involved. 		<ul style="list-style-type: none"> ■ When the Wi-Fi interface is dropped, or the holder or cable is damaged, disconnect the power supply plug or turn the breaker OFF. It may cause fire or electric shock. In this case, consult your dealer.
	<ul style="list-style-type: none"> ■ Children shall not play with the appliance. Cleaning and user maintenance shall not be made by children without supervision. 		<ul style="list-style-type: none"> ■ In case of an abnormal condition (such as a burning smell), stop the indoor unit and disconnect the power supply plug or turn the breaker OFF. A continued operation in the abnormal state may cause a malfunction, fire, or electric shock. In this case, consult your dealer.
	<ul style="list-style-type: none"> ■ Do not use the Wi-Fi interface nearby the medical electrical equipment or people who have a medical device such as a cardiac pacemaker or an implantable cardioverter-defibrillator. It can cause an accident due to malfunctions of the medical equipment or device. 		
	<ul style="list-style-type: none"> ■ Do not install the Wi-Fi interface nearby the automatic control devices such as automatic doors or fire alarms. It can cause accidents due to malfunctions. 		

⚠ Caution

(Improper handling may have consequences, including injury or damage to building.)



- Do not mount the Wi-Fi interface where children can reach. It can cause injury.
- Do not step on unstable stepstool to set up or clean the Wi-Fi interface. It may cause injury if you fall down.



- Do not use the Wi-Fi interface nearby other wireless devices, microwaves, cordless phones, or facsimiles. It can cause malfunctions.

[Precautions for installation, setting up, or use of the Wi-Fi interface]

Note

- Please ensure that the Router supports the WPA2-AES encryption setting before commencement of the installation of this Wi-Fi interface.
- The End user should read and accept the terms and conditions of the Wi-Fi service before commencement of the installation of this Wi-Fi interface.
- To complete connection of this Wi-Fi interface to the Wi-Fi service the Router may be required.
- This Wi-Fi interface will not commence transmission of any operational data from the system until the End user registers and accepts the terms and conditions of the Wi-Fi service.
- This Wi-Fi interface should not be installed and connected to any Mitsubishi Electric system which is to provide application critical cooling or heating.
- Please write down the model information and more on the last page "Setting information", when you install this Wi-Fi interface.

Mitsubishi Electric's Wi-Fi Interface is designed for communication to Mitsubishi Electric's MELCloud Wi-Fi service.

Third party Wi-Fi interfaces cannot be connected to MELCloud.

Mitsubishi Electric is not responsible for any (i) underperformance of a system or any product; (ii) system or product fault; or (iii) loss or damage to any system or product; which is caused by or arises from connection to and/or use of any third party Wi-Fi interface or any third party Wi-Fi service with Mitsubishi Electric equipment.

For the latest information regarding MELCloud from Mitsubishi Electric Corporation, please visit www.MELCloud.com

2. Product Introduction

No.	Item	Description
1	MODE switch	It selects modes.
2	RESET switch	It resets the system and ALL settings.
3	ERR LED (Orange)	It shows the network error state.
4	NET LED (Green)	It shows the network state.
5	MODE LED (Orange)	It shows the Access point mode state.
6	UNIT LED (Green)	It shows the indoor unit state.

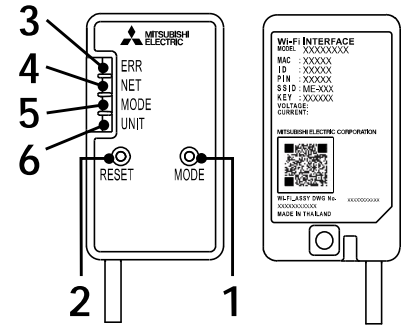

(1) MODE switch







- The MODE switch is used for selecting modes in configurations.

(2) RESET switch

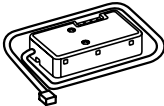
- Hold down the RESET switch for 2 seconds to reboot the system.
- Hold down the RESET switch for 14 seconds to initialize the Wi-Fi interface to the factory default.

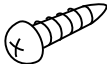
When the Wi-Fi interface is reset to the factory default, ALL the configuration information will be lost. Take great care in implementing this operation.

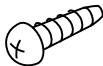
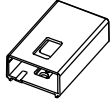
3. Parts

①	Interface unit (with connecting cable)		1	④	Mounting cord clamp		1
②	Fixing screw for ⑥ 3.5×16 mm		2	⑤	Fastener (for bundling the wires)		1
③	Fixing screw for ④ 4×16 mm		1	⑥	Holder		1
				⑦	Clip		1

4. Connecting the Wi-Fi interface

(For details on each system, see the relevant instruction manual.)

Turn off the breaker of the room air conditioner or the ATW unit before connecting the cable to the indoor unit.

Refer to the installation manual of each model for connecting instructions and details.

(1) The connecting cable connected to a indoor unit (CN105) should be mounted at the indoor unit or its vicinity.

When mounting the Interface unit ① inside an indoor unit, refer to the installation manual of the indoor unit. Do not mount the Interface unit ① inside the indoor unit, if not mentioned.

<Room air conditioner>

When mounting on the wall

The cable side of the interface unit ① should face downward.

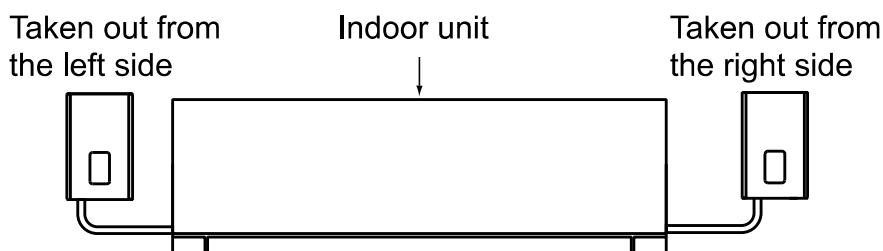

- Mount the holder ⑥ on the wall so its mark for the cable faces downward.
- Insert the interface unit ① into the holder ⑥ until it clicks.
Note: Tighten the upper and then the lower screws; adjust and level the holder ⑥ using the elongated hole for the lower screw.

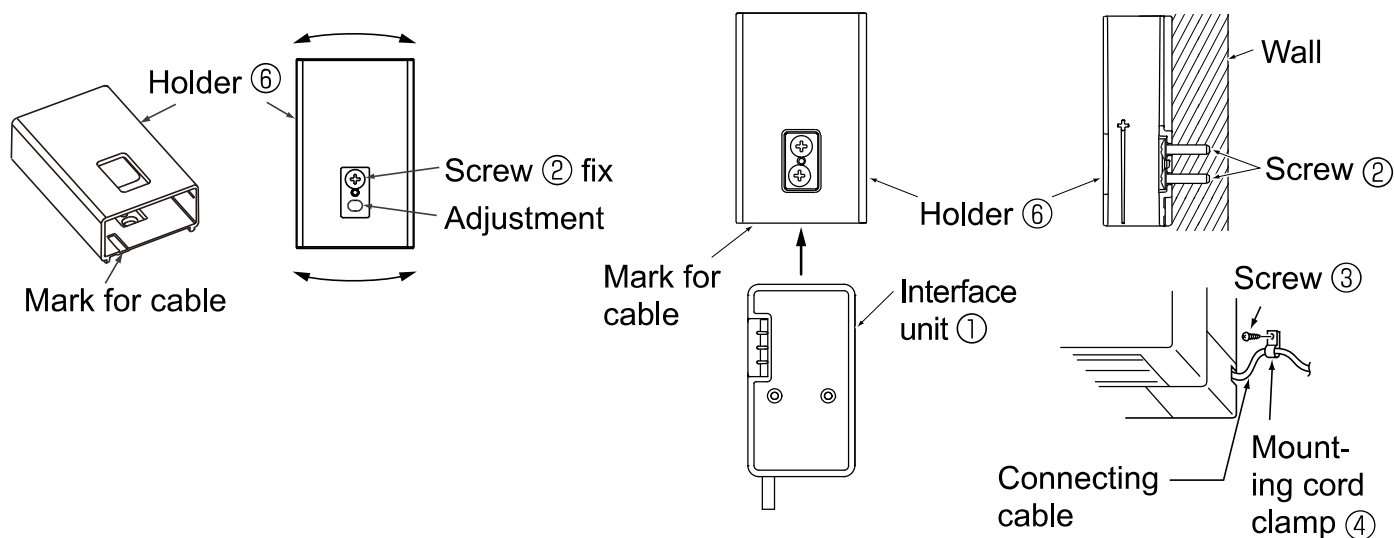

When mounting on the outer side of indoor unit

- Insert the clip ⑦ into the holder ⑥ until it clicks.
 - Insert the interface unit ① into the holder ⑥ until it clicks.
- Note: When inserting the interface unit ① into the holder, align the cable of the Interface unit ① with the mark for the cable on the holder ⑥.
- Otherwise, light leakage or degradation in appearance may result.

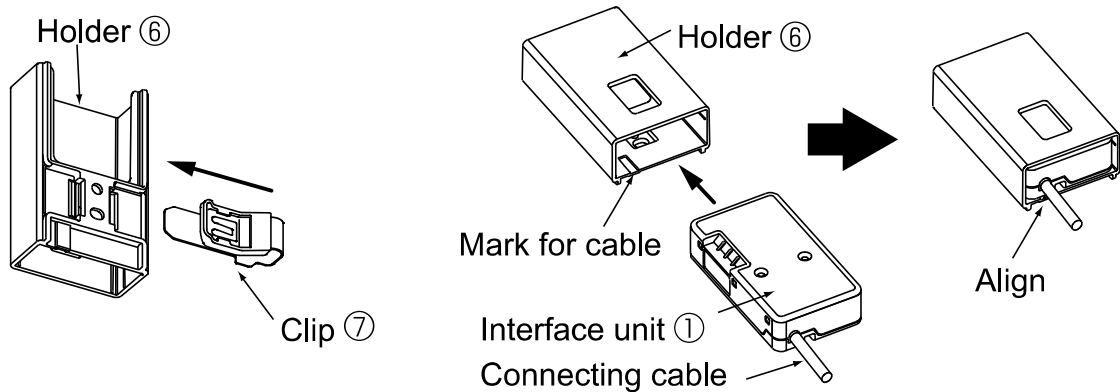

- Slip the clip ⑦ over the edge of corner box to fix the interface unit ①.
- Note: Mount the interface unit ① on the underside of the indoor unit if it cannot be mounted on the side of the indoor unit.

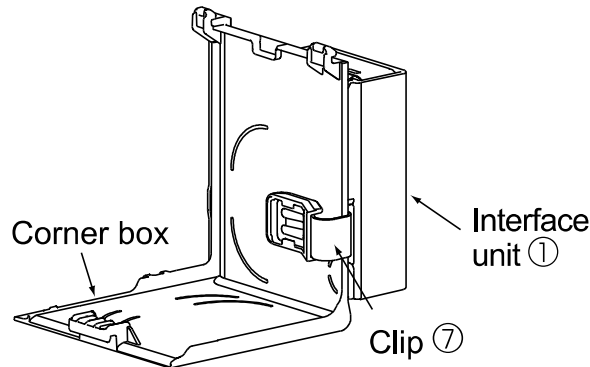

Example of mounting on the left side of indoor unit

Note: Interface unit ① can also be mounted on the right side of the indoor unit.

Underside of the Indoor unit

Side of the Indoor unit

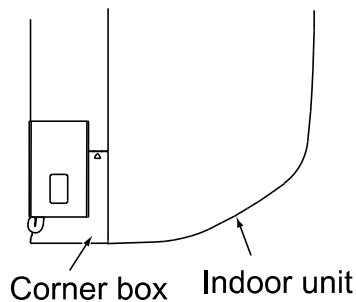
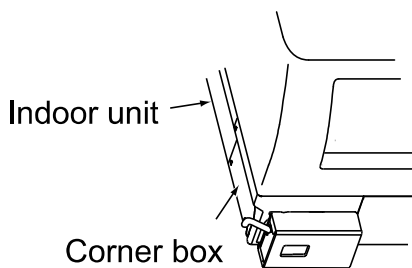

- To check the LED indication after setup, remove the interface unit ① from the holder ⑥.

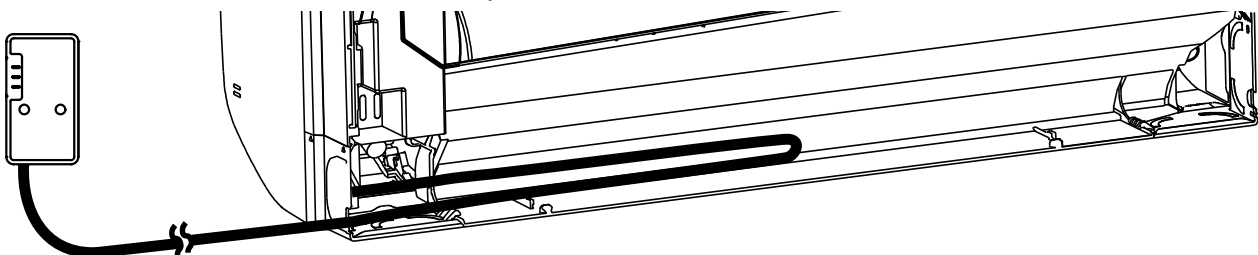

Run the connecting cable in the space on the back of the unit as shown in the above figure. Tuck cabling away and secure it.

Note: Make sure that the connecting cable will not get caught on or between the installation plate and the wall, or between the indoor unit and the installation plate. Failure to do so may cause damage to the connecting cable resulting in communication problems.

<ATW indoor unit>

Cylinder unit

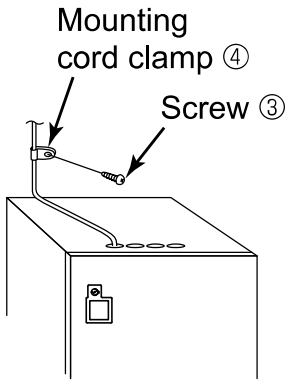

Hydrobox

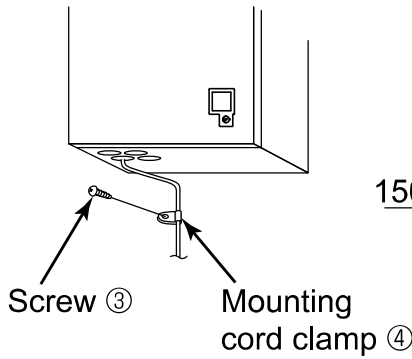

Connecting to Cylinder unit

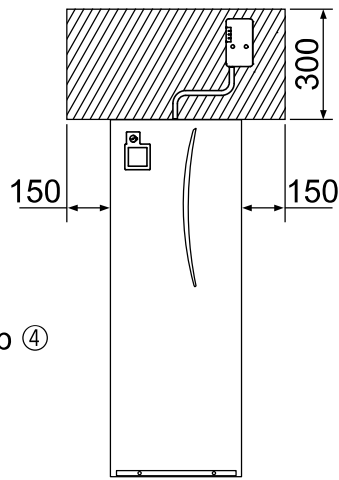

Connecting to Hydrobox

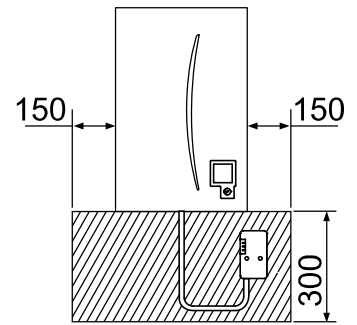

GB

Mount in the same procedure for room air conditioner. Please refer to “When mounting on the wall” on page 6.

(2) Turn on the breaker of the room air conditioner or the ATW unit and check that the LED indication of the Wi-Fi interface enters the initial state shown on right.

Initial State

ERR	OFF
NET	OFF
MODE	OFF
UNIT	Flashing

Setting up
 Refer to **SETUP QUICK REFERENCE GUIDE** (Included in same package) and **SETUP MANUAL** to connect to a Router for setting up.
 For **SETUP MANUAL**, please go to the website below.
www.MELCloud.com/Support

For **MELCloud User Manual**, please go to the website below.
www.MELCloud.com/Support

5. Specifications

Input Voltage	DC12.7 V (from indoor unit)
Power consumption	MAX 2 W
Size H×W×D (mm)	79×44×18.5
Weight (g)	110 (including cable)
Transmitter power level (MAX)	17.5 dBm @IEEE 802.11b
RF channel	1ch ~ 13ch (2412~2472 MHz)
Radio protocol	IEEE 802.11b/g/n (20)
Encryption	AES
Authentication	WPA2-PSK
Software Ver	XX.00
Length of cable (mm)	2,040

For Declaration of Conformity, please go to the website below.
www.MELCloud.com/Support

Setting information

Indoor unit model name	
Indoor unit serial number	
Outdoor unit model name	
Outdoor unit serial number	
Wi-Fi interface MAC address (MAC)	
Wi-Fi interface serial number (ID)	
Wi-Fi interface PIN (PIN)	
Wi-Fi interface SSID (SSID)	
Wi-Fi Interface KEY (KEY)	
System commissioning date	
Wi-Fi interface installation date	

Installer contact details

Name	
Telephone number	

MEMO

.....

.....

.....

.....

.....

Name of Importer:

Mitsubishi Electric Europe B.V.
Capronilaan 46, 1119 NS, Schiphol Rijk, The Netherlands

French Branch
25, Boulevard des Bouvets, 92741 Nanterre Cedex, France

German Branch
Mitsubishi-Electric-Platz 1, 40882 Ratingen, Germany

Belgian Branch
Autobaan 2, 8210 Loppem, Belgium

Irish Branch
Westgate Business Park, Ballymount, Dublin 24, Ireland

Italian Branch
Centro Direzionale Colleoni, Palazzo Sirio-Ingresso 1
Viale Colleoni 7, 20864 Agrate Brianza(MB), Italy

Norwegian Branch
Gneisveien 2D, 1914 Ytre Enebakk, Norway

Portuguese Branch
Avda. do Forte, 10, 2799-514, Carnaxide, Lisbon, Portugal

Spanish Branch
Carretera de Rubi 76-80 - Apdo. 420 08173 Sant Cugat del Valles (Barcelona), Spain

Scandinavian Branch
Hammarbacken 14, P.O. Box 750 SE-19127, Sollentuna, Sweden

UK Branch
Travellers Lane, Hatfield, Herts., AL10 8XB, England, U.K.

Polish Branch
Krakowska 50, PL-32-083 Balice, Poland

MITSUBISHI ELECTRIC TURKEY ELEKTRİK ÜRÜNLERİ A.Ş.
Şerifali Mah. Kale Sok. No: 41 34775 Ümraniye, İstanbul / Turkey

MITSUBISHI ELECTRIC (RUSSIA) LLC
52, bld.1 Kosmodamianskaya Nab. 115054, Moscow, Russia

This product is designed and intended for use in the residential,
commercial and light-industrial environment.

mitsubishi electric corporation

HEAD OFFICE: TOKYO BUILDING, 2-7-3, MARUNOUCHI, CHIYODA-KU, TOKYO 100-8310, JAPAN

mitsubishi electric consumer products (thailand) co., ltd
AMATA NAKORN INDUSTRIAL ESTATE 700/406 MOO 7, TAMBON DON HUA ROH, AMPHUR
MUANG, CHONBURI 20000, THAILAND
